

## Radar System Using Arduino

Prof. D.A.Ghoghre<sup>1</sup>, Ahire Dhanshri<sup>2</sup>, Ahire Priyanka<sup>3</sup>

1(Assistant Prof., E&TC, LoGMIEER/SPPU, India)

2, 3(Student, E&TC, LoGMIEER/SPPU, India)

**Abstract :** RADAR is an object detection system which uses Microwaves. Microwaves are nothing but the radio waves. It uses microwaves to determine the Range, Altitude and Direction or Speed of objects. The radar dish or antenna transmits pulses of radio pulses which returns back from any object in their path. Arduino is a single board microcontroller. It is to make using electronics in multidisciplinary projects more accessible. This project focus at making a Radar which is efficient, cheaper and reflects all the possible techniques that a radar consists of.

**Keywords:** RADAR, Microwaves, Arduino, etc.

### I. Introduction

RADAR is an object detection system which uses radio waves to determine the range, altitude, direction, or speed of objects. Radar systems come in a variety of sizes and have different performance specifications. Some radar systems are used for air-traffic control at airports and others are used for long range surveillance and early-warning systems. A radar system is the heart of a missile guidance system. Small portable radar systems that can be maintained and operated by one person are available as well as systems that occupy several large rooms [1].

Radar was secretly developed by several nations before and during the World War II. The term RADAR itself, not the actual development, was coined in 1940 by United States Navy as an acronym for Radio Detection and ranging. The modern uses of radar are highly diverse, including air traffic control, radar, astronomy, air-defense systems, antimissile systems, antimissile systems; marine radars to locate landmarks and other ships; aircraft anti-collision systems; ocean surveillance systems, outer space surveillance and rendezvous systems; meteorological precipitation monitoring; altimetry and flight control precipitation monitoring; altimetry and flight control systems; guided missile target locating systems; and ground-penetrating radar for geological observations. High tech radar systems are associated with digital signal processing. [1]

### II. Literature Survey

*Table 2.1: Literature Survey*

Sr.No	Author	Work of Result	Year
1	Christian Hulsmeyer	Use of radio echo to detect ship	1904
2	Robart Alexander Watson-Watt	Robart Alexander Watson-watt	1939

### III. System Overview

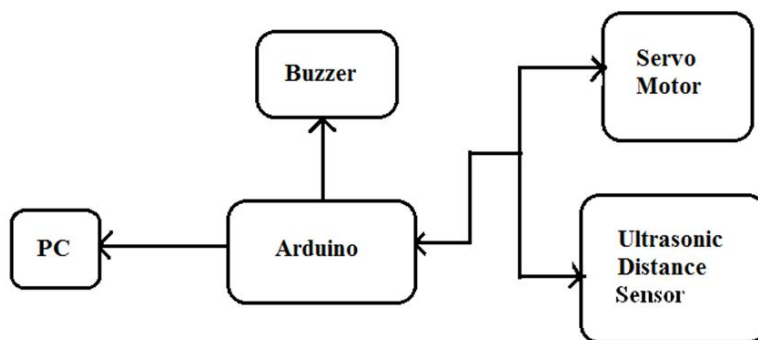

*Fig 3.1: Block diagram of RADAR system*

- Ultrasonic distance sensor - ultrasonic sensor generate high frequency sound wave and evaluate the echo which is received back by the sensor. The modules includes ultrasonic transmitters, receiver and control circuit. The basic principle of work:
  - (1) Using IO trigger for at least 10us high level signal,
  - (2) The Module automatically sends eight 40 kHz and detect whether there is a
  - (3) Pulse signal back.
  - (4) IF the signal back, through high level , time of high output IO duration is
  - (5) The time from sending ultrasonic to returning.
  - (6) Test distance = (high level time × velocity of sound (340M/S) /2
- Servo motor – It is used as a rotary actuator that allows for precise control of angular poision, velocity a acceleration. A servo system mainly consists of three basic components - a controlled device, a output sensor, a feedback system. This is an automatic closed loop control system. Here instead of controlling a device by applying the variable input signal, the device is controlled by a feedback signal generated by comparing output signal and reference input signal.



Fig:3.2:servo motor

- Arduino – It is a single board microcontroller used to control the function of servo motor and ultrasonic sensor. It sends the angular information to servo motor on which the motor rotates and sensor works as per that directions.
- Buzzer – It is used for indication purpose. When an object is detected by the system buzzer rings as an indication for object detection.

Ultrasonic sensor, servo motor and are connected to Arduino. The output of Arduino is given to buzzer and PC for the purpose of display. Ultrasonic sensor continuously emits waves. Echo of this waves are received by the receiver and is processed by using software. Time required for the echo to receive is calculated. Thus it detects object, calculates the distance and display the object graphically on PC as well as LCD.

#### IV. Flowchart

The flowchart shows the overall operation of system in accordance with software

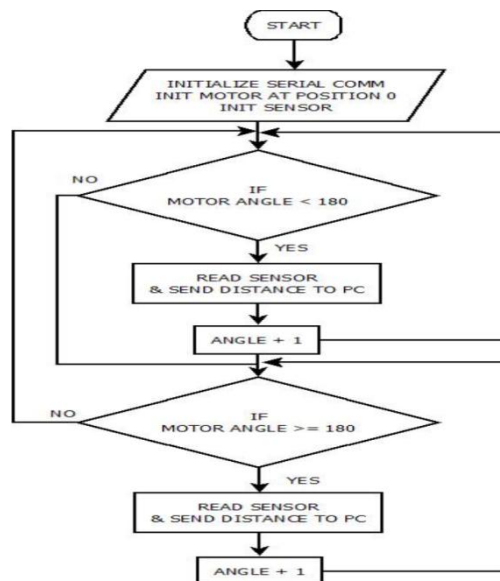

## V. Result

Hardware Module Of Project

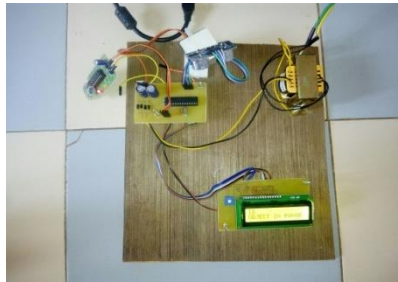

*Fig 4.1: Hardware Module Of Project*

Wireless Module Of The Project

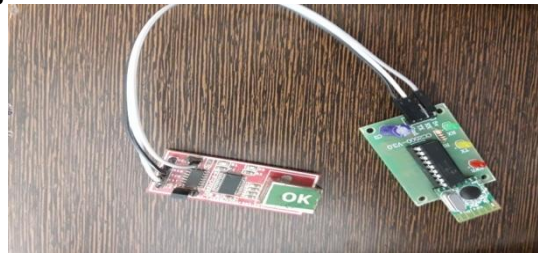
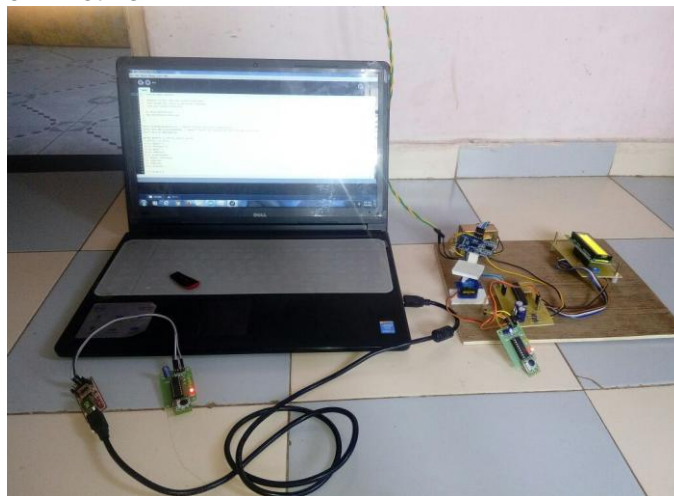

Figure shows the wireless module of the project

*Fig 4.2: CC2500 Module*

COMPLETE MODULE OF PROJECT



*Fig 4.3: Complete system*

## VI. Applications

- As a security purpose.
- For military application.
- Object detection

## VII. Conclusion

This project aims on the use of Ultrasonic Sensor by connected to the Arduino UNO R3 board and the signal from the sensor further provided to the screen formed on the laptop to measure the presence of any obstacle in front of the sensor as well as determine the range and angle at which the obstacle is detected by the sensor. We implemented this project successfully and the result are obtained as per desired. Motor will rotate  $15^{\circ}$  to  $165^{\circ}$  for the object detection in the range of 3meter. when the object is within the range motor will stop for some time and on graph which is shown on the screen will indicated red color line that mean object is detected and it also measure the distance of object from source point

### **References**

- [1]. Dr. Anuj Dutt- “Arduino Based RADAR System”
- [2]. [2] Nithya.V, Robin Alias<sup>2</sup>, Sreepriya N. S, Vivek Joseph,Yathukrishna.K.T-“Ultrasonic RADAR”,Vol.4, No.3, March 2016,E-ISSN:2321-9637
- [3]. <http://www.arduino.cc/date-7/9/1016>, time-11:35 AM
- [4]. [www.datasheetcatalog.com](http://www.datasheetcatalog.com)
- [5]. <http://www.atmel.com/atmega328>